

THIS DRAWING IS UNPUBLISHED. RELEASED FOR PUBLICATION  
 © COPYRIGHT - BY TYCO ELECTRONICS CORPORATION. ALL RIGHTS RESERVED.

LOC	DIST	REVISIONS			
P	LTR	DESCRIPTION	DATE	DWN	APVD
		D1	ECR-06-023927(REDRAWN IN AUTOCAD)	10NOV06	HMR GP

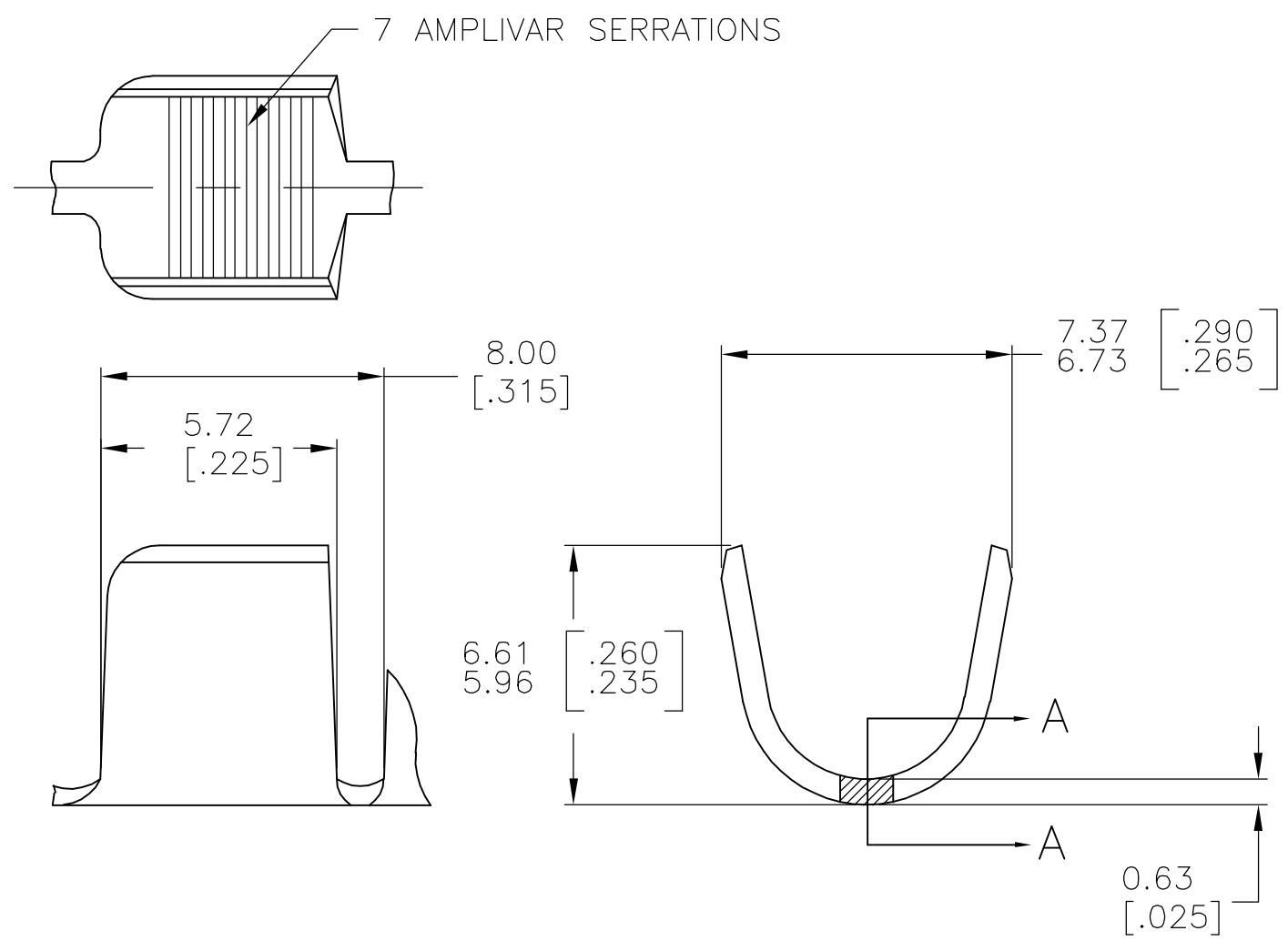

- CONTINUOUS STRIP ON REELS.
- DIMENSIONS IN BRACKETS ARE IN INCHES.
- FOR ADDITIONAL INFORMATION, SEE APPLICATION SPEC. 114-2002.
- WIRE RANGE: 7000-12000 CMA.
- CRIMP WIDTH: .250 F TYPE (AMPLIVAR PIGTAIL)  
 CRIMP HEIGHT (±.002)=(TOTAL CMA+27,100)/423,700  
 GENERAL APPLICATION GUIDELINES MUST BE FOLLOWED AS SPECIFIED IN CATALOG #82221  
 FOR APPLICATOR INFORMATION CALL:1-800-722-1111  
 FOR PRODUCT INFORMATION CALL:1-800-522-6752

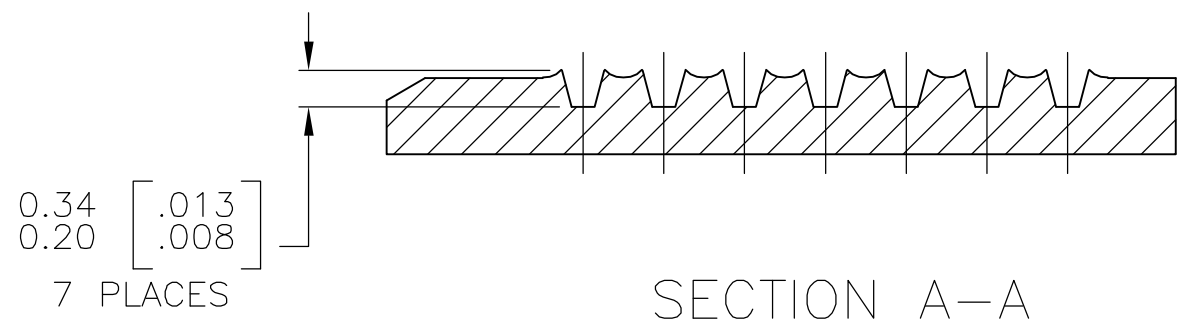

SECTION A-A  
SCALE 20:1

NONE	62295-2
TIN PLATE	62295-1
FINISH	PART NO

THIS DRAWING IS A CONTROLLED DOCUMENT.		DWN RAGHAVENDRA 10NOV06	Tyco Electronics Corporation Harrisburg, PA 17105-3608				
DIMENSIONS: mm [INCHES]	TOLERANCES UNLESS OTHERWISE SPECIFIED:	CHK G.D.PORTA	NAME				
	0 PLC ± -	APVD G.D.PORTA	PRODUCT SPEC				
	1 PLC ± -	PRODUCT SPEC	APPLICATION SPEC				
MATERIAL BRASS	FINISH SEE TABLE	2 PLC ± -	SIZE	CAGE CODE	DRAWING NO	RESTRICTED TO	
		3 PLC ± 0.38 [.015]	A3	00779	C-62295	-	
		4 PLC ± -	CUSTOMER DRAWING		SCALE 6:1	SHEET 1 OF 1	REV D1
		ANGLES ± 1' 0'					